



## Merlin Gas Detection Panel: GDP4



## Installation & Operation Manual

Please read this manual carefully and retain for future use.

S&S Northern provide a range of detection panels which can be used in many applications such as factories, car parks, shopping centres and most commonly - boiler houses.

The GDP4 can be used with up to twelve (12) Merlin gas detectors (sold separately) for monitoring and detecting gas including carbon monoxide, liquid petroleum gas and methane. The GDP4 can also be integrated with a BMS, fire alarm and remote emergency shut-off buttons.

## Table of contents

<b>INSTALLATION .....</b>	<b>3</b>
Planning.....	3
Fixing .....	3
Board Overview .....	4
Wiring the GDP4.....	5
BMS Wiring and Set-Up Switch .....	6
Auto Reset Set-Up Switch.....	7
Zone 1 - 4 Set-Up Switches .....	7
Factory Set Condition .....	7
Trouble Shooting .....	7
Specification .....	8
<b>OPERATION .....</b>	<b>9</b>
First Power Up .....	9
LED Indicator Status .....	9
Mute & Reset Buttons.....	10
Servicing & General Maintenance .....	10
Bump Testing .....	10
<b>IMPORTANT WARNING STATEMENTS .....</b>	<b>11</b>
Manufacturer's Warranty.....	11
Installation Details.....	12

# INSTALLATION

## Planning

The Merlin GDP4 is a four zone gas detection panel which can be used in many applications such as factories, car parks, shopping centres and most commonly - boiler houses.

It can be used with up to twelve Merlin gas detectors for monitoring and detecting gas including carbon monoxide, liquid petroleum gas and methane.

The GDP4 system can be integrated with, but not limited to, a BMS (building management system) a fire panel, external alarms and remote emergency shut-off buttons.



Please refer to your detector manual for important information regarding coverage, location and positioning including areas and conditions to avoid.

Locations for detectors will vary based on the intended application and target gas, they should be located near identified sources of a potential gas leaks/ pockets where hazardous gas could quickly accumulate and areas of identified consequential risk.

The composition of the target gas and its density relative to air are used as the basis for any recommended height of sensors.

Generally, the installation height of a sensor for a heavy gas (such as propane) would be close to the lowest point in the area, and for a light gas (such as methane) would be close to the highest point in the area. Any recommended heights may vary based on air flow and temperature conditions in addition to the proposed application and location – this is particularly apparent with oxygen depletion sensors, and the target gas that they are used for.

## Fixing

### Unpack all the parts!

1. Carefully remove the front cover and board from the unit by unscrewing the four bolts located at each corner. To do this – use the socket wrench provided.
2. Mark the four screw holes located on the back of the enclosure to the wall. Ensure the wall surface is flat to prevent base distortion.
3. After executing the mounting and the connections – replace the front cover and insert the security caps over the four bolts.



Be careful when creating access for cables – Damage to boards will void any warranty.

## Board Overview

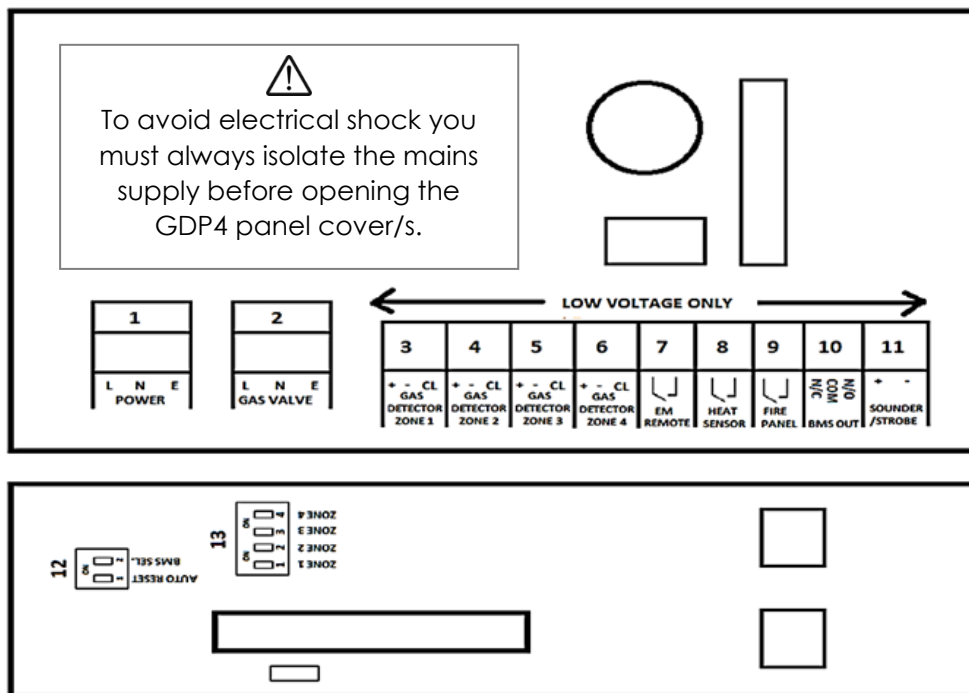

1. 100-240VAC Mains power Input
  2. 100-240VAC Gas Solenoid Valve Power Output.
  3. 24VDC Gas detector power supply (Zone 1) purchased separately.
  4. 24VDC Gas detector power supply (zone 2) purchased separately.
  5. 24VDC Gas detector power supply (zone 3) purchased separately.
  6. 24VDC Gas detector power supply (zone 4) purchased separately.
  7. Remote emergency stop buttons (Volt free) purchased separately).
  8. Heat Sensor: Fusible Links (Volt free) purchased separately
  9. Fire panel connection (Volt free) not included.
  10. BMS output contacts. Normally Open, Common and Normally Closed.
  11. 24VDC Sounder/ Strobe alarm - purchased separately
  12. Switch - BMS Selection & Auto Reset
  13. Switch - Zone 1, 2, 3 & 4 enable/disable
- Fuse – 3.15A

## Wiring the GDP4

⚠

Always power down the panel when wiring external circuits to prevent damage to electronics.

⚠

Mains supply must be connected by a competent person and according to any regulations.

### ⚡ MAINS POWER CONNECTION

100-240V AC mains power should be supplied to the **[POWER]** connector using a 3 core cable and fused at 3A.

On connecting the mains supply to the panel the power LED indicator will light up – this is located on the front cover.

### ⚡ VALVE OUTPUT

100-240V AC electrical power supplied from the **[GAS VALVE]** connector using a 3 core cable can be connected to a gas solenoid valve which can shut the gas supply on alarm status.

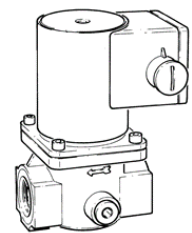

Refer to your valve manual for more information and wiring!

### GAS DETECTORS

A 12-24V power supply to gas detectors are wired to **[GAS DETECTOR ZONE]** terminals. These connections are [+,-] and [CL] and can be connected to a Merlin gas detector.

Multiple detector wiring.

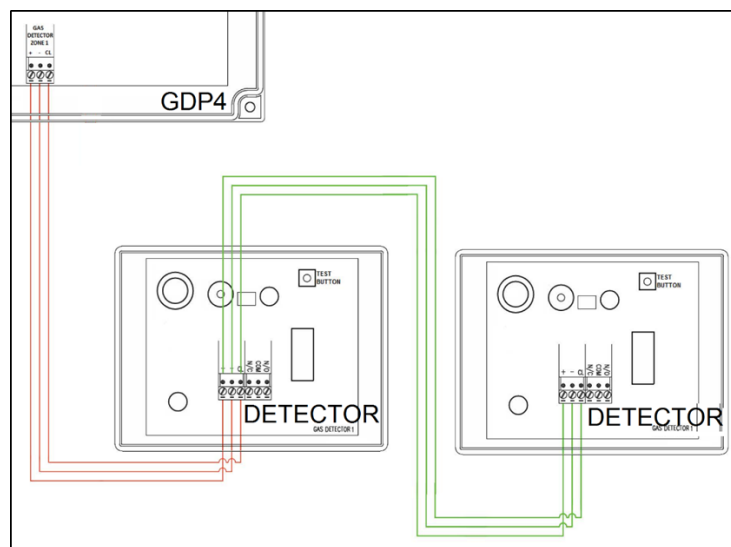

## REMOTE EMERGENCY STOP BUTTONS

The terminal for remote emergency shut-off buttons is detailed on the circuit board as [EM REMOTE]. These connections are linked out as a factory setting.

Remote emergency shut-off buttons should be volt free and wired to the Merlin GDP4 using two-core cable.

## HEAT SENSOR

The terminal for heat detectors is detailed on the circuit board as [HEAT SENSOR].

These connections are linked out as a factory setting.

Heat detectors should be volt free and wired to the Merlin GDP4 using two-core cable.

## FIRE PANEL

The terminal for fire alarms is detailed on the circuit board as [FIRE PANEL].

These connections are linked out as a factory setting.

Fire alarms should be volt free and wired to the Merlin GDP4 using two-core cable.

## SOUNDER / STROBES

There are connections for an external sounder alarm/ strobe lighting to activate on alarm.

Refer to your sounder/ strobe manual for wiring.

## BMS Wiring and Set-Up Switch

Connections are available on the board for Building Management Systems.

[NO] [COM] [NC] These are volt free connections.

This is a relay that changes state in alarm or when the gas is on/off and can be used in conjunction with other external relays that affect other devices and controls such as purge fans and audible alarms etc.

The GDP4 can be integrated with a BMS to make or break a circuit on gas on/gas off, (valve open or valve closed). This will tell the BMS whether or not electrical power is being sent to the solenoid.

There is a dip-switch located on the GDP4 circuit board labelled [BMS].

This is factory set to 'OFF' position which signals the BMS on gas on/gas off.

When switched to 'ON', the GDP4 will only signal the BMS on a fault, i.e. gas detected, EM Stop pressed, etc.

BMS SWITCH	BMS SIGNAL
OFF	Gas on or off only.
ON	Error condition i.e. gas detected, emergency stop pressed.

## Auto Reset Set-Up Switch

The GDP4 has a built-in auto reset feature.

There is a dip-switch located on the GDP4 circuit board labelled [Auto].

This is factory set in the 'Off' position i.e. when power is restored after a power cut or loss, the panel has to be restarted manually. When switched to 'On', the system will restart automatically when power is restored.

AUTO SWITCH	CONDITION
OFF	GDP4 has to be restarted manually following power cut/ loss.
ON	GDP4 will automatically restart when power is restored.

## Zone 1 - 4 Set-Up Switches

There are dip-switches located on the GDP4 circuit board labelled [ZONE 1] to [ZONE 4].

This is factory set in the 'Off' position. For each of the gas detector zones you are using please ensure that the relevant zone has being enabled. The zones you are not using should be left disabled.

ZONE 1/2/3/4 SWITCH	CONDITION
OFF	Gas detection zone disabled.
ON	Gas detection zone enabled.

## Factory Set Condition

SWITCH	CONDITION
BMS	OFF
AUTO RESET	OFF
ZONE 1	OFF
ZONE 2	OFF
ZONE 3	OFF
ZONE 4	OFF

## Trouble Shooting

Fault.	Possible Cause/Correction.
Detector not responding.	<ul style="list-style-type: none"> <li>○ Incorrect wiring</li> <li>○ Zone switches not properly configured</li> </ul>
Panel not responding.	<ul style="list-style-type: none"> <li>○ Incorrect Wiring</li> <li>○ No Power</li> <li>○ Auto-Reset not properly configured</li> </ul>

**Specification**

Product:	Gas Detection Panel
Model:	GDP4
Power Input Voltage	100-240V AC
Gas Valve Output Voltage	100-240V AC
BMS Output	3A
Current Consumption	20W max (full load)
Internal Fuse	3.15A
Operating Temperature	0 – 50°C 30-85%RH Non-Condensing
Audible Alarm Buzzer dB	65 dB (300mm distance in quiet conditions)
Housing Material	Polylac PA-765
Flame Rating	UL 94
Approvals	CE, RoHS
O/All Dimensions (H x W x D) mm / inch	180 x 255 x 77mm



# OPERATION

## First Power Up

On connecting mains power, press reset to start the testing sequence.

The system will close the solenoid valve when an emergency stop has been pressed, gas has been detected or any alarm signal has been triggered.

When the system is connected to the mains power supply, the Power LED will illuminate RED.

## LED Indicator Status

### Power

When the system is connected to the mains power supply, the Power LED will illuminate RED.

When no power is present, this LED will not light up.

### Gas On

On start up the Gas on LED will flash for one minute to check for gas being detected.

If no gas detected or any other faults the gas valve will open and the Gas On LED will illuminate.

GREEN = Gas On

OFF = Gas Off

If the test is unsuccessful the relevant zone LED light will illuminate to indicate a fault.

### EM Stop

If an emergency shut off button (either remote or on the panel) is pressed, the LED will illuminate AMBER and the gas will be turned off.

The EM Stop button must be re-set before restarting the system.

OFF = OK

AMBER = EM Stop button pressed

### Heat Detector

Under normal working conditions this LED is off. If the fusible link melts at 72 Degrees Celsius or higher, the LED will show AMBER and the Gas valve will turn off.

### Fire Alarm

If the fire alarm panel has been activated, the LED will illuminate Amber and the gas will be turned off. The Fire alarm panel must be re-set before restarting the system.

Off = OK

AMBER = Fire alarm activated.

### Zones 1-2-3-4

Under normal working conditions this LED is GREEN.

If the gas detector connected reaches the low level alarm this will show AMBER.

If the gas detector connected reaches high level alarm this will show RED and the gas solenoid valve will close if connected.

## Mute & Reset Buttons

### MUTE

The mute button is located on the front fascia of the GDP4 and is used to mute the sounder inside the board when in alarm.

The internal buzzer operates at approximately 90db measured 30cm from a closed panel.

The mute button is used to mute the sounder inside the board when in alarm.

### RESET

The reset button is located on the front fascia of the GDP4 and is used to turn the system on and to reset the system following alarm.

## Servicing & General Maintenance



It is recommended that detectors are inspected and serviced at least annually from the date of installation for optimum performance and protection.

- ✓ DO carefully remove any accumulated dust from the outer enclosure once a month.
- ✗ NEVER use detergents or solvents to clean your detectors – this may permanently or temporarily damage the gas sensing elements.
- ✗ NEVER spray lighter gas, paint or other aerosols near the detectors.
- ✗ NEVER paint the device. Paint will seal vents and may interfere with the device.

## Bump Testing

### What is bump testing?

'Bump testing' is a term used for checking a gas detector is functioning correctly by exposing it to the target gas. A known concentration of the target gas is applied to the sensor to trigger an alarm condition and ascertain the detector is working safely.

### Why is it important?

A detector may visually appear in good order, but its sensitivity can be inhibited by external factors. Dust, humidity, temperature fluctuations, cleaning products, contaminants or sensor drift (ageing) can cause a decline in sensitivity and eventual failure. Regular 'bump tests' are important to make sure the detector is able to detect a release of gas as early as possible.

### How often?

A 'bump test' takes seconds and is often completed alongside a scheduled fire alarm test. Current British standards recommend that for new installations - it may be prudent to carry out a bump test frequently (perhaps weekly), following a successful initial period and as confidence grows in the installation concerned, the frequency could be reduced.

Please remember, 'bump testing' does not remove the need to have gas detectors inspected, calibrated and serviced periodically by a trained engineer.

For more help and advice on bump testing, calibration and service – contact us.

## IMPORTANT WARNING STATEMENTS

Please take the time to thoroughly read this user's guide which should be retained for future reference.

It is recommended that this device be commissioned upon installation and serviced at least annually.

Do not apply lighter gas or other aerosols to detectors – this will cause extreme damage to the gas sensing elements.

High concentrations of alcohol found in many products may damage, deteriorate or affect the gas sensing elements of the detectors – Avoid exposure near your devices.

This device is designed to detect the gas in the designated zone area from any source of combustion or dangerous level. It is NOT designed to detect smoke, fire or other gases and should NOT be used as such.

This device provides early warning of the presence of gas, usually before a healthy adult would experience symptoms. This early warning is possible provided your alarm is located, installed and maintained as described in this guide.

Never ignore your device when in alarm. Actuation of your alarm indicates the presence of an error or significant issue that requires immediate attention.

This device requires a continual supply of electrical power – it will not work without power.

This device should not be used to substitute proper installation, use and/or maintenance of fuel burning appliances including appropriate ventilation and exhaust systems.

This device does not prevent dangerous gasses from occurring or accumulating.

This unit may not fully safeguard individuals with specific medical conditions. If in doubt, consult a doctor/physician.

Your product should reach you in perfect condition, if you suspect it is damaged, contact your supplier.

### Manufacturer's Warranty

#### 3 Year Manufacturer's Warranty

**Warranty coverage:** The manufacturer warrants to the original consumer purchaser, that this product will be free of defects in material and workmanship for a period of three (3) years from date of purchase. The manufacturer's liability hereunder is limited to replacement of the product with repaired product at the discretion of the manufacture. This warranty is void if the product has been damaged by accident, unreasonable use, neglect, tampering or other causes not arising from defects in material or workmanship. This warranty extends to the original consumer purchaser of the product only.

**Warranty disclaimers:** Any implied warranties arising out of this sale, including but not limited to the implied warranties of description, merchantability and intended operational purpose, are limited in duration to the above warranty period. In no event shall the manufacturer be liable for loss of use of this product or for any indirect, special, incidental or consequential damages, or costs, or expenses incurred by the consumer or any other user of this product, whether due to a breach of contract, negligence, strict liability in tort or otherwise. The manufacturer shall have no liability for any personal injury, property damage or any special, incidental, contingent or consequential damage of any kind resulting from gas leakage, fire or explosion. This warranty does not affect your statutory rights.

**Warranty Performance:** During the above warranty period, your product will be replaced with a comparable product if the defective product is returned together with proof of purchase date. The replacement product will be in warranty for the remainder of the original warranty period or for six months – whichever is the greatest.

---

#### Information on waste disposal for consumers of electrical & electronic equipment.



When this product has reached the end of its life it must be treated as Waste Electrical & Electronics Equipment (WEEE). Any WEEE marked products must not be mixed with general household waste, but kept separate for the treatment, recovery and recycling of the materials used. Please contact your supplier or local authority for details of recycling schemes in your area.

## Installation Details

Please pass this manual to the system owner or system user.

Date of Installation:	
Installation Location:	
Organisation:	
Stamp/ Signature of the installer:	

Contact Us:

### **S&S Northern Head Office**

Tel: +44(0) 1257 470 983

Fax: +44(0) 1257 471 937

[www.snsnorthern.com](http://www.snsnorthern.com)

[info@snsnorthern.com](mailto:info@snsnorthern.com)

### **South East Division**

Tel: +44(0) 1702 291 725

Fax: +44(0) 1702 299 148

[south@snsnorthern.com](mailto:south@snsnorthern.com)



S&S Northern is the owner of this document and reserves all rights of modification without prior notice.